



DS2200

Reference Manual

DATALOGIC

DS2200

REFERENCE MANUAL



DATALOGIC

DATALOGIC S.p.A.
Via Candini 2
40012 - Lippo di Calderara di Reno
Bologna - Italy

DS2200 Reference Manual

Ed.: 4/2006

ALL RIGHTS RESERVED

Datalogic reserves the right to make modifications and improvements without prior notification.

Datalogic shall not be liable for technical or editorial errors or omissions contained herein, nor for incidental or consequential damages resulting from the use of this manual.

Product names mentioned herein are for identification purposes only and may be trademarks and or registered trademarks of their respective companies.

© Datalogic S.p.A. 1998 - 2006

21/04/06

CONTENTS

REFERENCES	v
Conventions	v
Reference Documentation	v
Services and Support	v
SAFETY PRECAUTIONS	vi
Laser Safety	vi
Power Supply	viii
WEEE Compliance	viii
GENERAL VIEW	ix
GUIDE TO INSTALLATION	x
1 INTRODUCTION	1
1.1 Product Description	1
1.1.1 Indicators	2
1.2 Model Description	2
1.3 Accessories	3
2 INSTALLATION	4
2.1 Package Contents	4
2.2 Mechanical Installation	5
2.2.1 Mounting DS2200	6
2.3 Electrical Connections	7
2.3.1 Power Supply	8
2.3.2 Main Serial Interface - RS485 Half-Duplex	8
2.3.3 Auxiliary Interface - RS232	9
2.3.4 Inputs	10
2.3.5 Outputs	11
2.4 Positioning	11
2.5 Typical Layouts	13
2.5.1 Point-to-Point	13
2.5.2 RS485 Master/Slave	13
2.5.3 Multiplexer	15
3 READING FEATURES	16
3.1 Step-Ladder Mode	16
3.2 Picket-Fence Mode	17
3.3 Performance	18
3.3.1 Raster	18
3.4 Reading Diagrams	19

4	MAINTENANCE	21
4.1	Cleaning.....	21
5	TECHNICAL FEATURES	22
	GLOSSARY	24
	INDEX.....	28

REFERENCES

CONVENTIONS

This manual uses the following conventions:

“User” or “Operator” refers to anyone using a DS2100A.

“Device” refers to the DS2100A.

“You” refers to the System Administrator or Technical Support person using this manual to install, mount, operate, maintain or troubleshoot a DS2100A.

REFERENCE DOCUMENTATION

The documentation related to the DS2100A management is listed below:

- INT-30 20 mA Current Loop Interface Board for C-Box 100
- C-BOX 100 Installation Manual
- C-BOX 300/310 Installation Manual
- C-BOX 400/410 Installation Manual
- WinHost Help On Line

SERVICES AND SUPPORT

Datalogic provides several services as well as technical support through its website. Log on to **www.datalogic.com** and click on the links indicated for further information including:

- **PRODUCTS**

Search through the links to arrive at your product page where you can download specific **Manuals** and **Software & Utilities**

- **SERVICES & SUPPORT**

- **Datalogic Services** - Warranty Extensions and Maintenance Agreements
- **Authorised Repair Centres**

- **CONTACT US**

E-mail form and listing of Datalogic Subsidiaries

SAFETY PRECAUTIONS

LASER SAFETY

The following information is provided to comply with the rules imposed by international authorities and refers to the correct use of the DS2200 scanner.

Standard Regulations

This scanner utilizes a low-power laser diode. Although staring directly at the laser beam momentarily causes no known biological damage, avoid staring at the beam as one would with any very strong light source, such as the sun. Avoid that the laser beam hits the eye of an observer, even through reflective surfaces such as mirrors, etc.

This product conforms to the applicable requirements of both EN 60825-1 and CDRH 21 CFR 1040 at the date of manufacture. The scanner is classified as a Class 2 laser product according to EN 60825-1 regulations and as a Class II laser product according to CDRH regulations.

There is a safety device which allows the laser to be switched on only if the motor is rotating above the threshold for its correct scanning speed.

The laser beam can be switched off through a software command (see WinHost Help On Line or the "Command Strings for DS2200" file in the DS2200 directory).



WARNING

Use of controls or adjustments or performance of procedures other than those specified herein may result in exposure to hazardous visible laser light.

The laser light is visible to the human eye and is emitted from the window on the side of the scanner (Figure A, 2).

The warning label indicating exposure to laser light and the device classification is applied onto the body of the scanner (Figure A, 8):

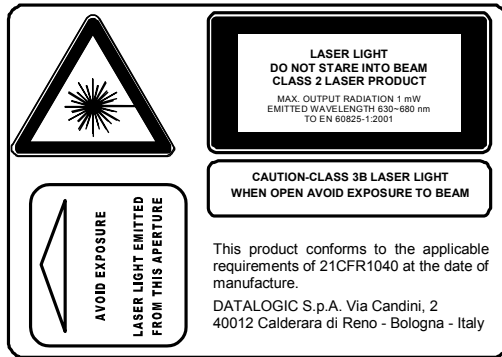

Warning and Device Class Label

For installation, use and maintenance it is not necessary to open the scanner.

The laser diode used in this device is classified as a Class 3B laser product according to EN 60825-1 regulations and as a Class IIIb laser product according to CDRH regulations. As it is not possible to apply a classification label on the laser diode used in this device, the following label is reproduced here:

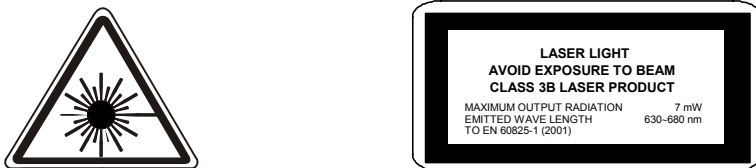

Laser Diode Class Label

Any violation of the optic parts in particular can cause radiation up to the maximum level of the laser diode (7mW at 630~680 nm).

POWER SUPPLY

- **This product is intended to be installed by Qualified Personnel only.**
- **DS2200 All Models:**
This device is intended to be supplied either by a UL Listed NEC Class 2 power source, or a UL listed ITE Limited Power Source (LPS), rated 5Vdc, minimum 0.4A.

WEEE COMPLIANCE



GENERAL VIEW

DS2200

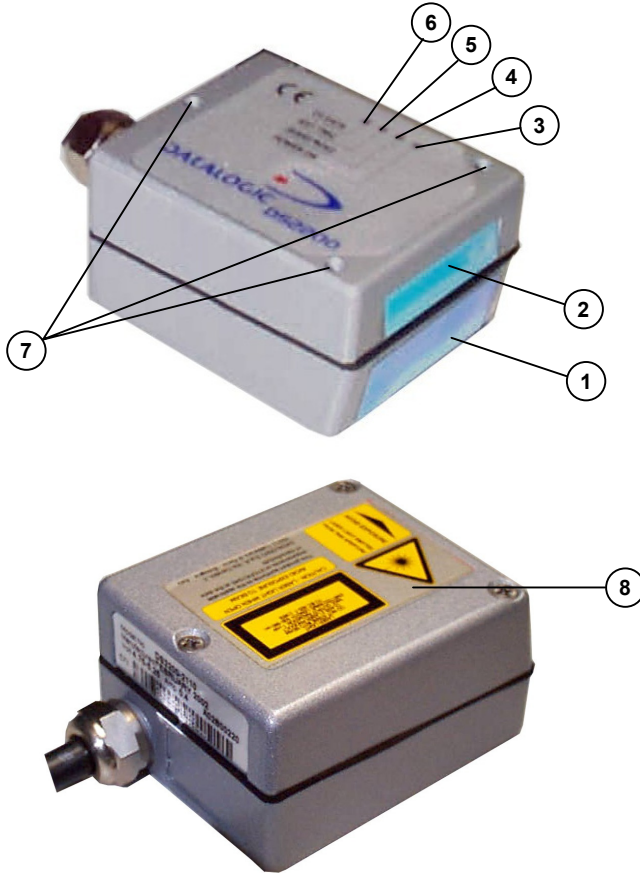

Figure A

- | | |
|------------------------------|--|
| ① Barcode Image Input Window | ⑤ Ext Trig LED |
| ② Laser Beam Output Window | ⑥ TX Data LED |
| ③ Power On LED | ⑦ Mounting Holes |
| ④ Good Read LED | ⑧ Laser Warning and Device Class Label |

GUIDE TO INSTALLATION

The following can be used as a checklist to verify all the necessary steps for complete installation of the DS2200 scanner.

1. Read all information in the section "Safety Precautions" at the beginning of this manual.
2. Correctly position and mount the scanner for barcode reading according to the information in par. 2.2, 2.4 and 3.4.
3. Provide correct system cabling according to the signals necessary (see all applicable sub-paragraphs under 2.3). See also sub-paragraphs under 2.5 for reference.
4. Install the Configuration Disk.
Upon successful completion of the installation, the readme.hlp file is opened, giving details about how to get started configuring your scanner.
See also the [Guide to Rapid Configuration](#) link.
Specific parameter details are available in the Help On Line.



NOTE

Fine tuning of the scanner position for barcode reading can be accomplished using the Test Mode as described in WinHost.

The installation is now complete.

1 INTRODUCTION

1.1 PRODUCT DESCRIPTION

The DS2200 scanner is a cost effective barcode reader complete with decoder designed to satisfy demanding requirements associated with high performance scanning.

The DS2200 ultra compact dimensions, based on Datalogic's experience in miniaturized laser components, make the scanner's integration into automated equipment extremely easy.

The DS2200 is easily configurable by means of the Windows-based user-friendly WinHost utility program provided on diskette, or through ESC sequences via the serial interface.

Some of the main features of DS2200 are listed below:

- miniaturized dimensions
- scanning speed: 500 scans/sec.
- linear, raster and high optical resolution versions
- 2 serial communication interfaces: RS232 + RS485 Half-Duplex
- reads all popular codes
- supply voltage: 5 Vdc
- test mode to verify the reading features and exact positioning of the scanner without the need for external tools
- programmable in 4 different operating modes to suit the most various barcode reading system requirements
- code verifier
- programmable input and output signals
- light source: solid state laser diode; the light emitted has a wave length of 630 ~ 680 nm. For laser safety precautions refer to the "Safety Precautions" section at the beginning of this manual
- low power consumption
- IP65 protection class of the enclosure; the reader is therefore suitable for industrial environments where high protection against harsh external conditions is required.

The laser beam output window is on the side of the scanner (Figure A, 2).

A security system allows the laser to activate only once the motor has reached the correct rotational speed; consequently, the laser beam is generated after a slight delay from the power on of the scanner.

1.1.1 Indicators

The four LEDs on the scanner indicate the following:

- POWER ON** (red), indicates the reader is connected to the power supply. (Figure A, 3).
- GOOD READ** (red), is used to signal the possibility of a successful barcode reading. (Figure A, 4).
- EXT TRIG** (yellow), indicates external trigger activity. Refer to par. 2.3.4. (Figure A, 5).
- TX DATA** (green), when blinking, indicates data transmission. (Figure A, 6).

The screw holes on the body of the reader are for mechanical fixture (Figure A, 7).

1.2 MODEL DESCRIPTION

The DS2200 scanner is available in versions that differ in regard to the following parameters:

- Optical Resolution.
- Linear or raster models.

The following models are therefore available:

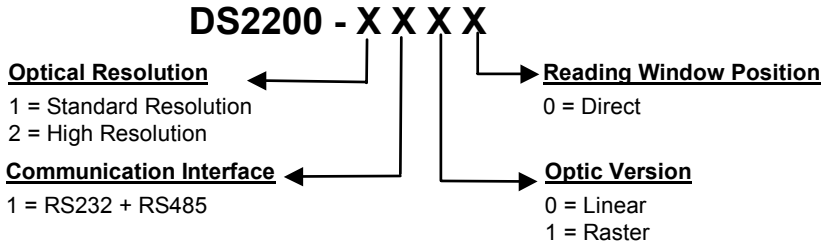

The following tables display each version's reading performance.

Version	Max Code Resolution	Speed
	mm (mils)	scans/s
1XXX	0.15 (6)	500
2XXX	0.07 (3)	500

Version	Reading Distance
1XXX	50 mm (2.0 in) - 220 mm (8.7 in) on 0.60 mm (24 mils) codes
2XXX	40 mm (1.6 in) - 125 mm (4.9 in) on 0.20 mm (8 mils) codes

See reading diagrams in par. 3.4 for further details.

1.3 ACCESSORIES

The following accessories are available on request:

Name	Description	Part Number
DC5-2200	DC converter 4-30 Vdc to 5 Vdc	93ACC1040
GFC-2200	90° Reading Device	93A201030

2 INSTALLATION

2.1 PACKAGE CONTENTS

Verify that the DS2200 reader and all the parts supplied with the equipment are present and intact when opening the packaging; the list of parts includes:

- DS2200 reader with cable
- Installation Manual
- Bar code test chart (PCS = 0.9)
- DS2200 configuration program disk
- Mounting kit: - bracket
- screws

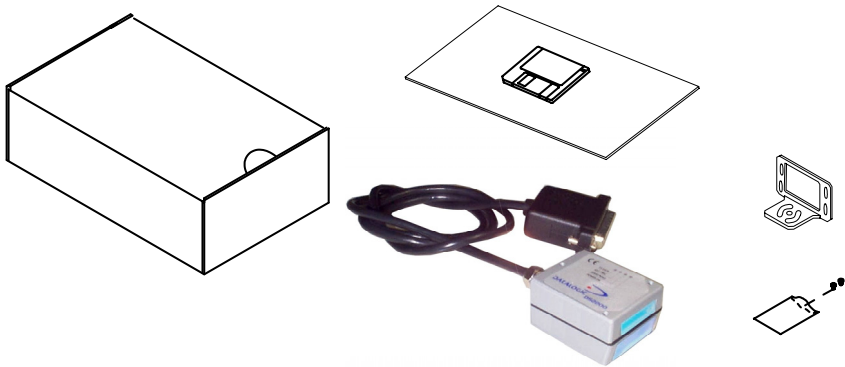
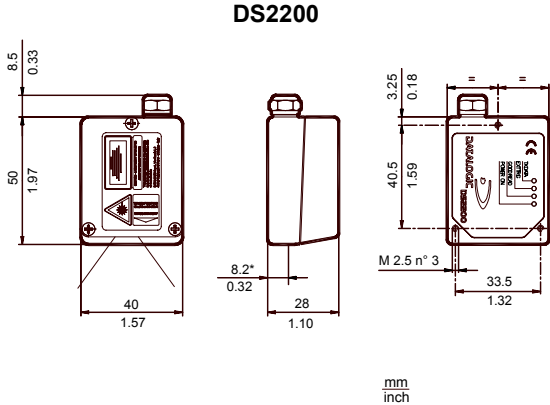

Figure 1 - DS2200 package contents

2.2 MECHANICAL INSTALLATION

DS2200 can be installed to operate in any position.

There are three screw holes (M2.5 x 5) on the body of the reader for mounting. The diagram below gives all the information required for installation; refer to par. 2.4 for correct positioning of the scanner with respect to the code passage zone.



* The quote refers to the scan line

MOUNTING BRACKET

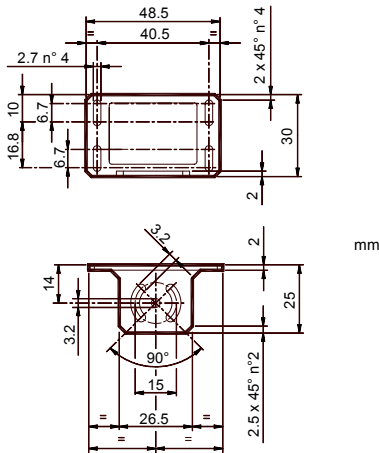
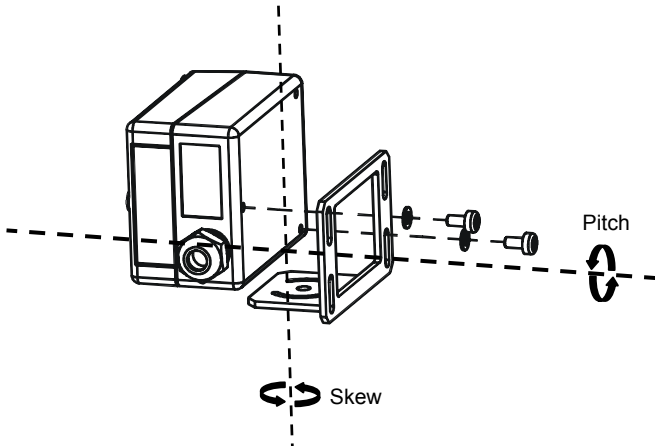

Figure 2 - DS2200 overall dimensions

2.2.1 Mounting DS2200

Using the DS2200 mounting bracket you can obtain the most suitable position for the reader as shown in the figure below:



2.3 ELECTRICAL CONNECTIONS

The DS2200 cable is equipped with a 25-pin female D-sub connector for connection with the power supply and input/output signals:



CAUTION Do not connect GND and SGND to different (external) ground references. GND and SGND are internally connected through filtering circuitry which can be permanently damaged if subjected to voltage drops over 0.8 Vdc.

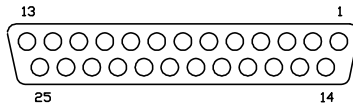

Figure 3 – 25-pin female D-sub connector

25-pin D-sub connector pinout		
Pin	Name	Function
9,13	VS	Power supply input voltage +
25	GND	Power supply input voltage -
1	CHASSIS	Chassis Ground
19	EXT TRIG-	External Trigger -
10, 12, 22	I/O REF	I/O reference
8	OUT1 +	Output 1 +
11	OUT2 +	Output 2 +
2	TXAUX	TX RS232 Aux. Interface
3	RXAUX	RX RS232 Aux. Interface
4	RTX485-	RTX- RS485 Main Interface
5	RTX485+	RTX+ RS485 Main Interface
7	SGND	Signal Ground
16	NGND	Internal Use - for Service only
17	FPE	Internal Use - for Service only
6, 14, 15, 18, 20, 21, 23, 24	NC	No Connect

2.3.1 Power Supply

The following pins of the DS2200 connector are used:

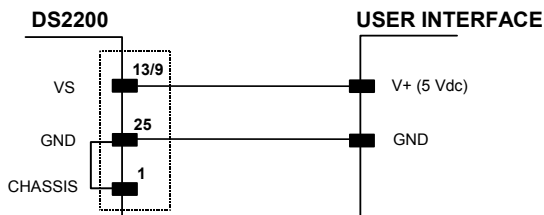

Figure 4 - Power supply connections

The power must be 5 Vdc only.

2.3.2 Main Serial Interface - RS485 Half-Duplex

The RS485 half-duplex interface (3 wires + shield) is used for polled communication protocols.

It can be used for Multidrop connections in a master/slave layout, or with a Datalogic Multiplexer (see par. 2.5.2 and 2.5.3).

The connector pinout follows:

Pin	Name	Function
5	RTX485+	RS485 transmitted/received data +
4	RTX485-	RS485 transmitted/received data -
7	SGND	signal ground

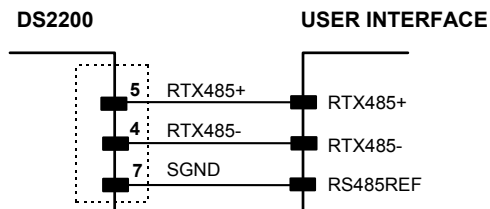

Figure 5 - RS485 half-duplex connections

For this interface type, the Multidrop Address must also be set via serial channel by the WinHost utility or by ESC sequences.

The following figure shows an example of a multidrop configuration between a Multiplexer and DS2200 scanners.

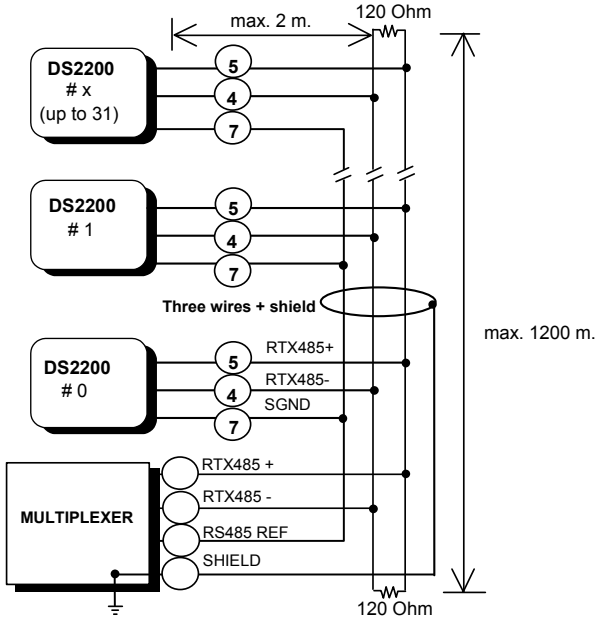

Figure 6 - DS2200 Multidrop connection to a Multiplexer

2.3.3 Auxiliary Interface - RS232

The auxiliary serial interface is used exclusively for RS232 point-to-point connections. It is also used for configuring the DS2200.

The parameters relative to the auxiliary interface (baud rate, data bits, etc.) can be defined using the WinHost utility program or "Host Mode Programming" installed from the diskette.

The following pins of the 25-pin connector are used to connect the RS232 auxiliary interface:

Pin	Name	Function
3	RXAUX	RS232 received data
2	TXAUX	RS232 transmitted data
7	SGND	signal ground

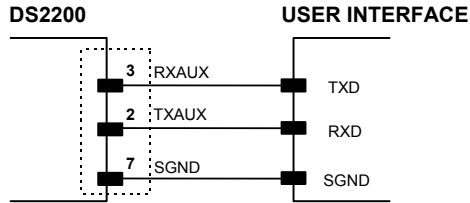

Figure 7 - RS232 auxiliary interface connections

2.3.4 Inputs

The inputs available on the connector supplied with the scanner are indicated below:

Pin	Name	Function
19	EXT TRIG-	external trigger (input -)
22	I/O REF	I/O reference

The EXT TRIG input is used to connect the external trigger which tells the scanner to scan for a code. The active state of this input is selected in software. Refer to the WinHost Help On Line.

The yellow LED (Figure A, 5) is on when EXT TRIG- is shorted to I/O REF.

This input was designed to be driven by an NPN type command. The connections are indicated in the following diagram:

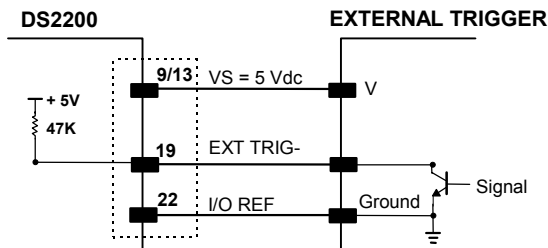

Figure 8 - External Trigger Input command

This input can be driven by an independently powered source, but the signal on EXT TRIG- must not exceed 9 Vdc.

An anti-disturbance hardware filter is implemented on the External Trigger input (< 5 milliseconds delay).

An additional 15 ms (typical) delay can be implemented through a dedicated software parameter (refer to WinHost Help On Line).

2.3.5 Outputs

Two general purpose outputs are available. These outputs can only be connected as open collector configurations. The following pins are present on the connector of the scanner:

Pin	Name	Function
8	OUT1+	output 1 +
11	OUT2+	output 2 +
10, 12, 22	I/O REF	I/O reference

The meaning of the two outputs OUT1 and OUT2 can be defined by the user (No Read, Right or Wrong). Refer to the WinHost Help On Line.

By default, OUT1 is associated with the No Read event, which activates when the code signaled by the External Trigger is not decoded, and OUT2 is associated with the Right event, which activates when the code is correctly decoded.

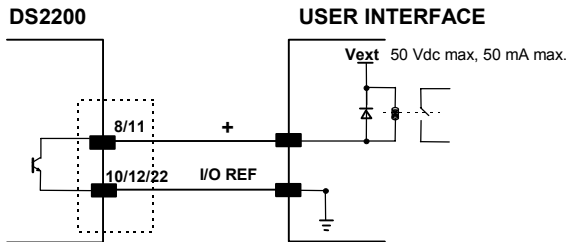

Figure 9 - DS2200 output connections

V_{CE} max = 50 Vdc
I max = 50 mA continuous

These outputs are both level or pulse configurable.

2.4 POSITIONING

The DS2200 scanner is able to decode barcode labels at a variety of angles, however significant angular distortion may degrade reading performance.

When mounting the DS2200 take into consideration these three ideal label position angles: **Pitch 0°**, **Skew 15° to 30°** and **Tilt 0°**.

Follow the suggestions for the best orientation:

The **Pitch** angle is represented by the value **P** in Figure 10. Position the reader in order to **minimize** the **Pitch** angle.

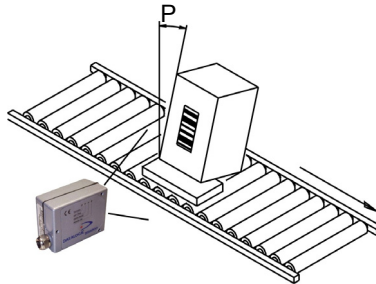

Figure 10 - Pitch Angle

The **Skew** angle is represented by the value **S** in Figure 11. Position the reader to **assure about 15°** for the **Skew** angle. This avoids the direct reflection of the laser light emitted by the DS2200.

For the raster version, this angle refers to the most inclined or external raster line, so that all other raster lines assure **more** than 15° Skew.

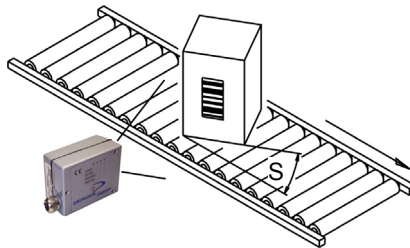

Figure 11 - Skew angle

The **Tilt** angle is represented by the value **T** in Figure 12. Position the reader in order to **minimize** the **Tilt** angle.

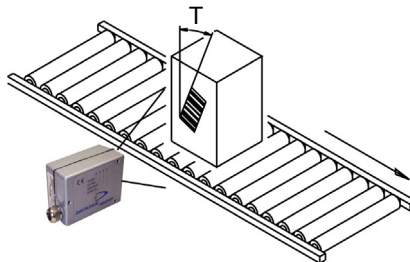

Figure 12 - Tilt angle

2.5 TYPICAL LAYOUTS

The following typical layouts refer to system hardware configurations. Dotted lines in the figures refer to optional hardware configurations within the particular layout.

These layouts also require the correct setup of the software configuration parameters. Complete software configuration procedures can be found in the **Guide To Rapid Configuration** in the WinHost Help On Line.

2.5.1 Point-to-Point

In this layout data is transmitted to the Host on the RS232 Auxiliary serial interface. The Local Echo communication mode must be enabled (default) see the WinHost Help On Line.

When On-Line Operating mode is used, the scanner is activated by an External Trigger (photoelectric sensor) when the object enters its reading zone.

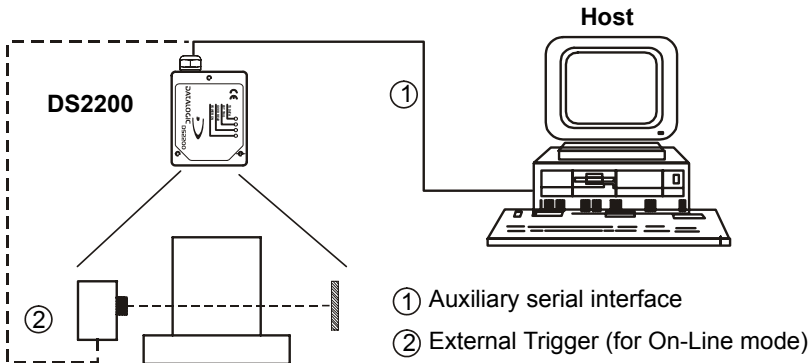

Figure 13 - Point to Point layout

2.5.2 RS485 Master/Slave

The RS485 Master/Slave connection is used to collect data from several scanners to build a multi-point or a multi-sided reading system; there can be one Master and up to 5 Slaves connected together.

The Slave scanners are connected together using the RS485 half-duplex main serial interface. Every Slave scanner must have a multidrop address in the range 0-4.

The Master scanner is also connected to the Host on the RS232 auxiliary serial interface.

The External Trigger signal is unique to the system; there is a single reading phase and a single message from the Master scanner to the Host computer.

It is necessary to bring the External Trigger signal to all the scanners.

The main and auxiliary ports are connected as shown in the figure below.

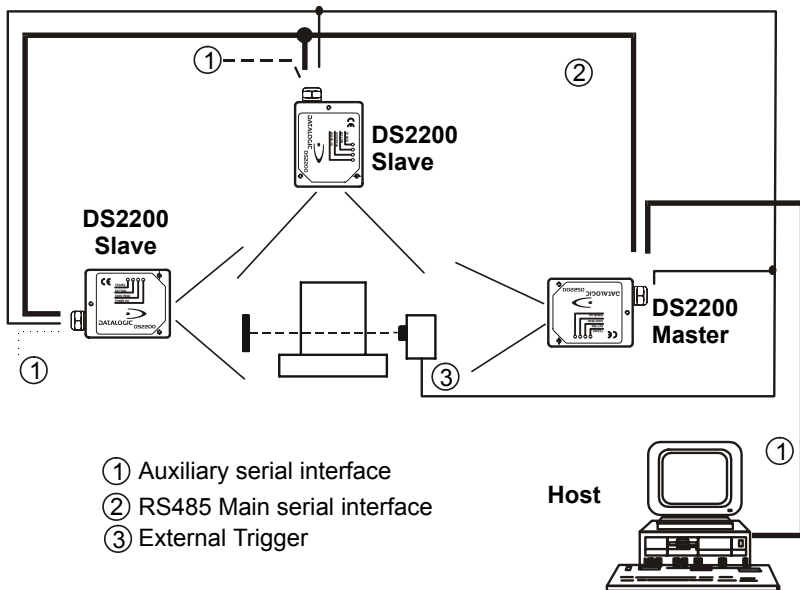

Figure 14 – Master/Slave layout



NOTE

The auxiliary serial port of the slave scanners can be used in Local Echo communication mode to control any single scanner (visualize data) or to configure it using the WinHost utility or Host Mode programming procedure.

The termination resistors of the RS485 bus must not be installed.

2.5.3 Multiplexer

Each scanner is connected to a Multiplexer (for example MX4000) with the RS485 half-duplex main interface.

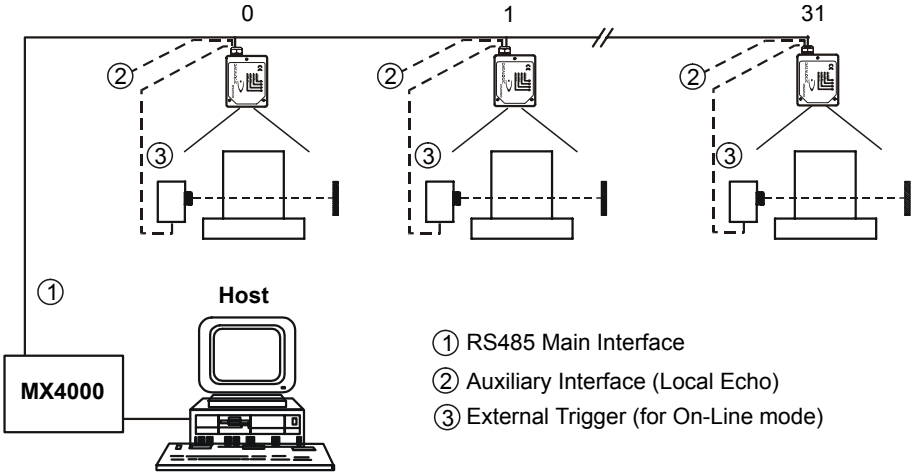

Figure 15 - Multiplexer layout

The auxiliary serial interface can be used in Local Echo mode to control any single scanner (visualize collected data) or to configure it using the WinHost utility or Host Mode programming procedure.

When On-Line Operating mode is used, the scanner is activated by an External Trigger (photoelectric sensor) when the object enters its reading zone.

3 READING FEATURES

The number of scans performed on the code by the DS2200 and therefore the decoding capability is influenced by the following parameters:

- number of scans per second
- code motion speed
- label dimensions
- scan direction with respect to code motion

At least 5 scans during the code passage should be allowed to ensure a successful read.

3.1 STEP-LADDER MODE

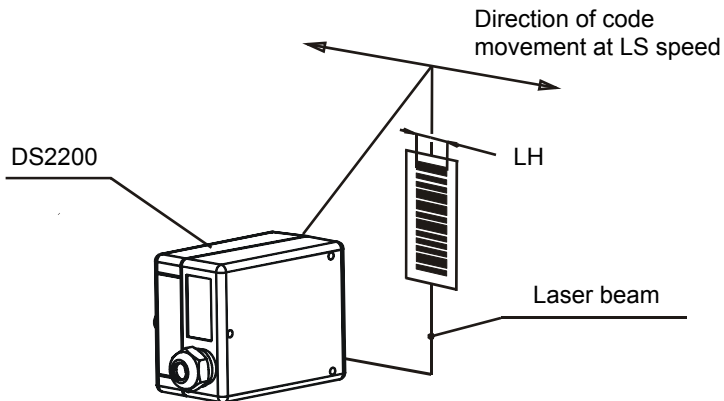

Figure 16 - "Step Ladder" scanning mode

If scanning is perpendicular to the code motion direction (Figure 16), the number of effective scans performed by the reader is given by the following formula:

$$SN = [(LH/LS) * SS] - 2$$

These symbols signify:

- SN = number of effective scans
- LH = label height (in mm)
- LS = label movement speed (in mm/s)
- SS = number of scans per second

For example, the DS2200 (500 scans/sec.) for a 25 mm high code moving at 500 mm/s performs:

$$[(25/500) * 500] - 2 = 23 \text{ effective scans.}$$

3.2 PICKET-FENCE MODE

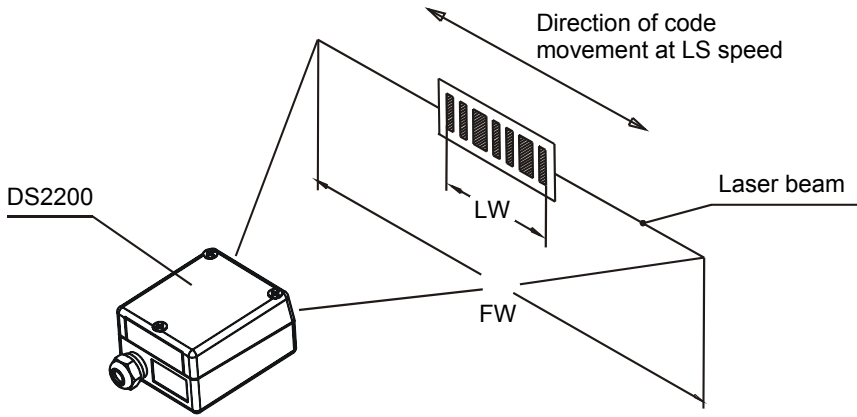

Figure 17 - "Picket Fence" scanning mode

If scanning is parallel to the code motion, (Figure 17), the number of effective scans is given by:

$$SN = [((FW-LW)/LS) * SS] - 2$$

These symbols signify:

- SN = number of effective scans
- FW = reading field width (in mm)
- LW = label width (in mm)
- LS = label movement speed (in mm/s)
- SS = scans per second

For example, for a 50 mm wide code moving in a point where the reading field is 100 mm wide at a 1000 mm/s speed, the DS2200 (500 scans per sec.), performs:

$$[((100-50)/1000) * 500] - 2 = 23 \text{ scans}$$

3.3 PERFORMANCE

The DS2200 scanner is available in different versions according to the reading performance.

Version	Max Code Resolution	Speed
	mm (mils)	scans/s
1XXX	0.15 (6)	500
2XXX	0.07 (3)	500

Version	Reading Distance
1XXX	50 mm (2.0 in) - 220 mm (8.7 in) on 0.60 mm (24 mils) codes
2XXX	40 mm (1.6 in) - 125 mm (4.9 in) on 0.20 mm (8 mils) codes

Refer to the diagrams given in par. 3.4 for further details on the reading features. these diagrams are taken on various resolution sample codes at a 25 °C ambient temperature, depending on the conditions listed under each diagram.

3.3.1 Raster

Raster versions are available. If standard devices do not satisfy specific requirements, contact your nearest Datalogic distributor, supplying code samples, to obtain complete information on the reading possibilities.

The max. capture of the Raster version is about 15 mm (0.6 in) at 220 mm (8.7 in).

3.4 READING DIAGRAMS

The following diagrams show the reading distance for barcodes with different densities.

DS2200-1XXX (Standard Resolution)

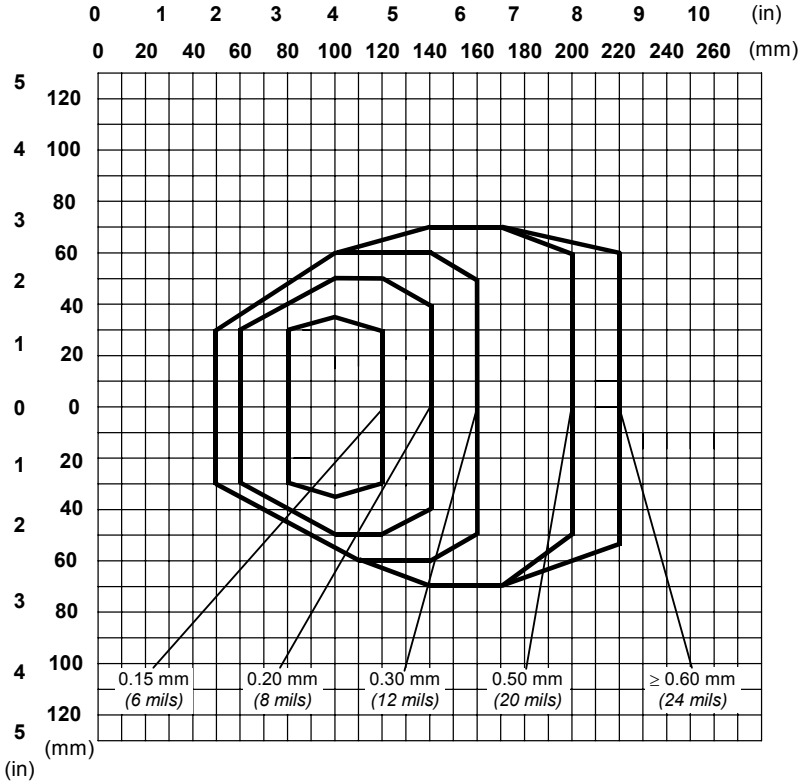

NOTE: (0,0) is the center of the laser beam output window

CONDITIONS:

- Code = Interleaved 2/5 or Code 39
- PCS = 0.90
- "Pitch" angle = 0°
- "Skew" angle = 15°
- "Tilt" angle = 0°

DS2200-2XXX (High Resolution)

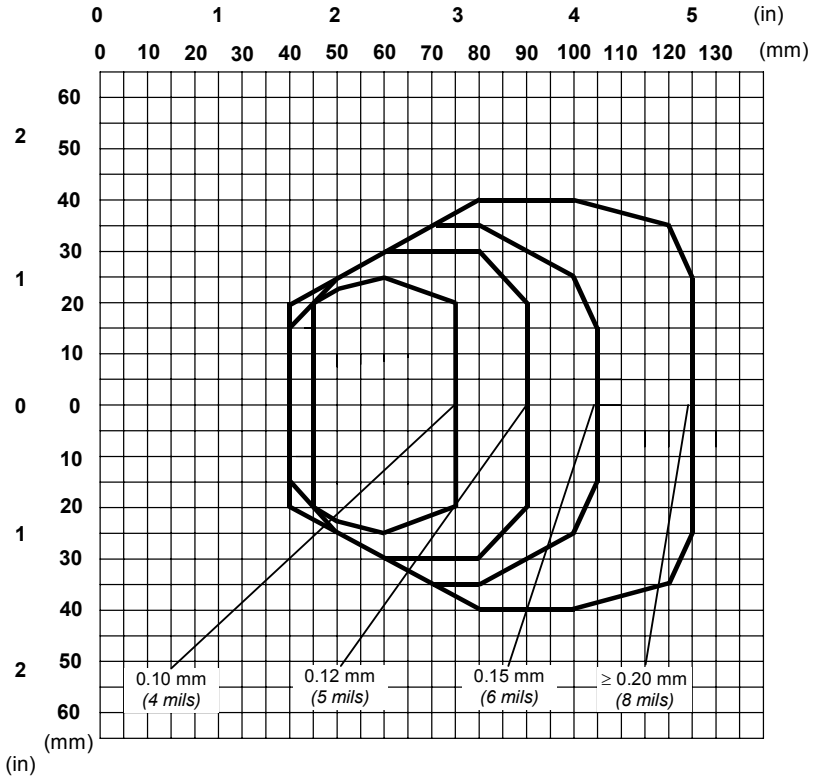

NOTE: (0,0) is the center of the laser beam output window.

CONDITIONS:

Code = Interleaved 2/5 or Code 39
 PCS = 0.90
 "Pitch" angle = 0°
 "Skew" angle = 15°
 "Tilt" angle = 0°

4 MAINTENANCE

4.1 CLEANING

Clean the windows periodically for continued correct operation of the reader.

Dust, dirt, etc. on the windows may alter the reading performance.

Repeat the operation frequently in particularly dirty environments.

Use soft material and alcohol to clean the windows and avoid any abrasive substances.



WARNING

Clean the windows of the DS2200 when the scanner is turned off or, at least, when the laser beam is deactivated.

5 TECHNICAL FEATURES

	DS2200-1XXX	DS2200-2XXX
ELECTRICAL FEATURES		
Power		
Maximum input voltage	5 Vdc \pm 5%	
Power consumption max.	2 W	
Serial Interfaces		
Main	RS485 Half-Duplex	
Auxiliary	RS232	
Baud Rates	150 to 115200	
Inputs		
External Trigger		
Outputs		
User-defined OUT1 and OUT2		
V _{CE} max.	50 Vdc	
Collector current max.	50 mA continuous	
V _{CE} saturation	0.3V at 10 mA max.	
Power dissipation max.	200 mW at 40 °C (Ambient temp.)	
OPTICAL FEATURES		
Light source	Semiconductor laser diode	
Wave length (Note 1)	630 ~ 680 nm	
Safety class	Class 2 - EN 60825-1; Class II - CDRH	
READING FEATURES (Note 2)		
Scan rate	500 scans/sec	
Aperture angle	52°	60°
Max. Reading distance	220 mm, (8.7 in)	125 mm (4.9 in)
Maximum resolution	0.15 mm (6 mils)	0.07 mm (3 mils)
USER INTERFACE		
LED indicators	Power ON, Good Read, Ext Trig, TX Data	

SOFTWARE FEATURES	
READABLE CODE SYMBOLOGIES <ul style="list-style-type: none"> • EAN/UPC (including Add-on 2 and Add-on 5) • 2/5 Interleaved • Code 39 (Standard and Full ASCII) • Codabar • Code 93 • Code 128 • EAN 128 • Pharmacode Other symbologies available on request	
Code Selection	up to six codes during one reading phase
Decoding Safety	can enable multiple good reads of same code
Headers and Terminators	up to four headers and four terminators
Operating Modes	On Line, Automatic, Serial On Line, Test
Configuration Modes	<ul style="list-style-type: none"> • through menus using WinHost utility • receiving commands from one of the serial ports (HOST MODE)
Parameter Storage	Non-volatile internal EEPROM
ENVIRONMENTAL FEATURES	
Operating temperature (Note 3)	0° to 40 °C (32° to 104 °F)
Storage temperature	-20° to 70 °C (-4° to 158 °F)
Humidity max.	90% non condensing
Vibration resistance IEC 68-2-6 test FC	14mm @ 2 to 10 Hz 1.5mm @ 13 to 55 Hz 2 g @ 70 to 200 Hz 2 hours on each axis
Shock resistance IEC 68-2-27 test EA	30g; 11 ms; 3 shocks on each axis
Protection class	IP65
PHYSICAL FEATURES	
Mechanical dimensions	50 x 40 x 28 mm (1.97 x 1.57 x 1.10 in.)
Weight without cable	about 160 g. (5.64 oz.)

Note 1: The features given are typical at a 25 °C ambient temperature (if not otherwise indicated).

Note 2: Further details given in par. 3.3 and 3.4.

Note 3: If the reader is used in high temperature environments (over 35 °C), use of the Beam Shutter is advised (see the WinHost configuration program).

GLOSSARY

Aperture

Term used on the required CDRH warning labels to describe the laser exit window.

Barcode

A pattern of variable-width bars and spaces which represents numeric or alphanumeric data in machine-readable form. The general format of a barcode symbol consists of a leading margin, start character, data or message character, check character (if any), stop character, and trailing margin. Within this framework, each recognizable symbology uses its own unique format.

Barcode Label

A label that carries a barcode and can be affixed to an article.

Baud Rate

A unit used to measure communications speed or data transfer rate.

CDRH (Center for Devices and Radiological Health)

This organization (a service of the Food and Drug Administration) is responsible for the safety regulations governing acceptable limitations on electronic radiation from laser devices. Datalogic devices are in compliance with the CDRH regulations.

Code Positioning

Variation in code placement that affects the ability of a scanner to read a code. The terms Pitch, Skew, and Tilt deal with the angular variations of code positioning in the X, Y and Z axes. See pars. 2.2.1 and 2.4. Variations in code placement affect the pulse width and therefore the decoding of the code. Pulse width is defined as a change from the leading edge of a bar or space to the trailing edge of a bar or space over time. Pulse width is also referred to as a transition. Tilt, pitch, and skew impact the pulse width of the code.

Decode

The process of translating a barcode into data characters using a specific set of rules for each symbology.

Decoder

As part of a barcode reading system, the electronic package which receives the signals from the scanner, performs the algorithm to interpret the signals into meaningful data and provides the interface to other devices. The decoder is normally integrated into the scanner.

EAN

European Article Number System. The international standard barcode for retail food packages.

EEPROM

Electrically Erasable Programmable Read-Only Memory. An on-board non-volatile memory chip.

Full Duplex

Simultaneous, two-way, independent transmission in both directions.

Half Duplex

Transmission in either direction, but not simultaneously.

Host

A computer that serves other terminals in a network, providing services such as network control, database access, special programs, supervisory programs, or programming languages.

Interface

A shared boundary defined by common physical interconnection characteristics, signal characteristics and meanings of interchanged signals.

LED (Light Emitting Diode)

A low power electronic device that can serve as a visible or near infrared light source when voltage is applied continuously or in pulses. It is commonly used as an indicator light and uses less power than an incandescent light bulb but more than a Liquid Crystal Display (LCD). LEDs have extremely long lifetimes when properly operated.

Multidrop Line

A single communications circuit that interconnects many stations, each of which contains terminal devices. See RS485.

Parameter

A value that you specify to a program. Typically parameters are set to configure a device to have particular operating characteristics.

Picket-Fence Orientation

When the barcode's bars are positioned vertically on the product, causing them to appear as a picket fence. The first bar will enter the scan window first. See par. 3.2.2.

Pitch

Rotation of a code pattern about the X-axis. The normal distance between center line or adjacent characters. See pars. 2.2.1 and 2.4.

Position

The position of a scanner or light source in relation to the target of a receiving element.

Protocol

A formal set of conventions governing the formatting and relative timing of message exchange between two communicating systems.

Raster

The process of projecting the laser beam at varied angles spaced evenly from each other. Typically, the mirrored rotor surfaces are angled to create multiple scan lines instead of a single beam.

Resolution

The narrowest element dimension which can be distinguished by a particular reading device or printed with a particular device or method.

RS232

Interface between data terminal equipment and data communication equipment employing serial binary data interchange.

RS485

Interface that specifies the electrical characteristics of generators and receivers for use in balanced digital multipoint systems such as on a Multidrop line.

Scanner

A device that examines a printed pattern (barcode) and either passes the uninterpreted data to a decoder or decodes the data and passes it onto the Host system.

Serial Port

An I/O port used to connect a scanner to your computer, identifiable by a 9-pin or 25-pin connector.

Signal

An impulse or fluctuating electrical quantity (i.e.: a voltage or current) the variations of which represent changes in information.

Skew

Rotation about the Y-axis. Rotational deviation from correct horizontal and vertical orientation; may apply to single character, line or entire encoded item. See pars. 2.2.1 and 2.4.

Step-Ladder orientation

When the barcode's bars are positioned horizontally on the product, causing them to appear as a ladder. The ends of all bars will enter the scan window first. See par. 3.2.1.

Symbol

A combination of characters including start/stop and checksum characters, as required, that form a complete scannable barcode.

Tilt

Rotation around the Z axis. Used to describe the position of the barcode with respect to the laser scan line. See pars. 2.2.1 and 2.4.

Trigger Signal

A signal, typically provided by a photoelectric sensor or proximity switch, which informs the scanner of the presence of an object within its reading zone.

UPC

Acronym for Universal Product Code. The standard barcode type for retail food packaging in the United States.

Visible Laser Diode

A light source used in scanners to illuminate the barcode symbol. Generates visible red light at wavelengths between 630 and 680 nm.

INDEX

A

Accessories; 3

C

Cleaning; 21

E

Electrical Connections; 7

G

General View; ix

Glossary; 24

Guide to Installation; x

I

Inputs; 10

Installation; 4

Interfaces

 Auxiliary – RS232; 9

 Main – RS485 Half Duplex; 8

L

Laser Safety; vi

LED Indicators; 2

M

Maintenance; 21

Model Description; 2

Mounting DS2200; 6

O

Outputs; 11

P

Package Contents; 4

Performance; 18

Picket-Fence Mode; 17

Positioning; 11

Power Supply; viii

R

Raster; 18

Reading Diagrams; 19

Reading Features; 16

Reference Documentation; v

S

Services and Support; v

Step-Ladder Mode; 16

T

Technical Features; 22

Typical Layouts; 13

 Multiplexer; 15

 Point-to-Point; 13

 RS485 Master/Slave; 13

W

WEEE Compliance; viii

dichiara che
declares that the
déclare que le
bescheinigt, daß das Gerät
declare que el

DS2200-XXXX Laser Scanner e tutti i suoi modelli
and all its models
et tous ses modèles
und seine modelle
y todos sus modelos

sono conformi alle Direttive del Consiglio Europeo sottoelencate:
are in conformity with the requirements of the European Council Directives listed below:
sont conformes aux spécifications des Directives de l'Union Européenne ci-dessous:
der nachstehend angeführten Direktiven des Europäischen Rats:
cumple con los requisitos de las Directivas del Consejo Europeo, según la lista siguiente:

89/336/EEC EMC Directive	e and et und y	92/31/EEC, 93/68/EEC	emendamenti successivi further amendments ses successifs amendements späteren Abänderungen succesivas enmiendas
---------------------------------	----------------------------	-----------------------------	---

Basate sulle legislazioni degli Stati membri in relazione alla compatibilità elettromagnetica ed alla sicurezza dei prodotti.

On the approximation of the laws of Member States relating to electromagnetic compatibility and product safety.

Basée sur la législation des Etats membres relative à la compatibilité électromagnétique et à la sécurité des produits.

Über die Annäherung der Gesetze der Mitgliedsstaaten in bezug auf elektromagnetische Verträglichkeit und Produktsicherheit entsprechen.

Basado en la aproximación de las leyes de los Países Miembros respecto a la compatibilidad electromagnética y las Medidas de seguridad relativas al producto.

Questa dichiarazione è basata sulla conformità dei prodotti alle norme seguenti:

This declaration is based upon compliance of the products to the following standards:

Cette déclaration repose sur la conformité des produits aux normes suivantes:

Diese Erklärung basiert darauf, daß das Produkt den folgenden Normen entspricht:

Esta declaración se basa en el cumplimiento de los productos con las siguientes normas:

**EN 55022 (Class A ITE), August 1994:
Amendment A1 (Class A ITE), October 2000:**

LIMITS AND METHODS OF MEASUREMENTS OF RADIO
DISTURBANCE CHARACTERISTICS OF INFORMATION
TECHNOLOGY EQUIPMENT

EN 61000-6-2, October 2001:

ELECTROMAGNETIC COMPATIBILITY (EMC)
PART 6-2: GENERIC STANDARDS - IMMUNITY FOR
INDUSTRIAL ENVIRONMENTS

Lippo di Calderara, 13/09/2005

Ruggero Cacioppo
Quality Assurance Supervisor